

# **ULTRA**

**INDUSTRIES, INC.**

**Industrial Air Filtration Equipment**



**PULSE - JET DUST COLLECTORS**

# ...a word about **ULTRA** INDUSTRIES, INC.

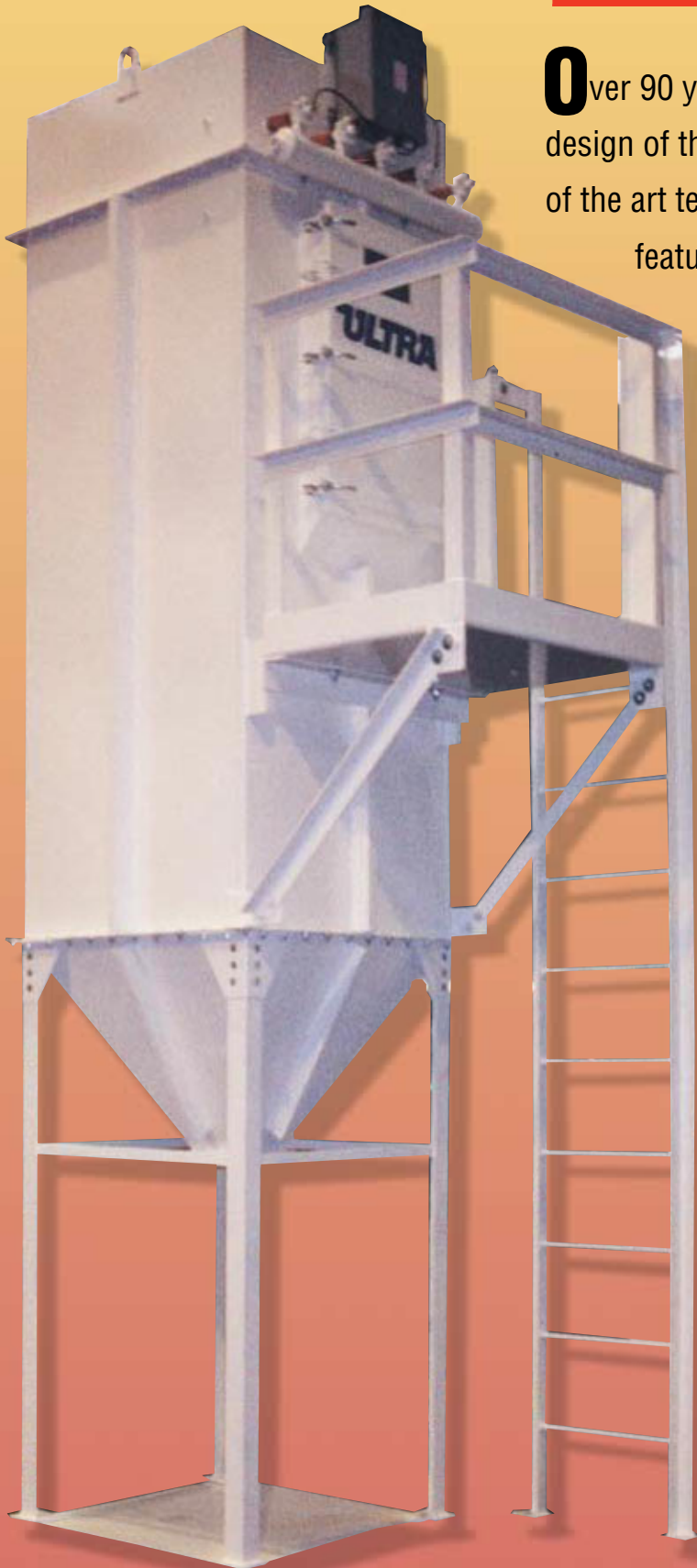

**O**ver 90 years of experience has gone into the design of the **Ultra Industries** collector. It features state of the art technology and incorporates the best product features and components found in the industry.

**Ultra Industries** has an experienced staff of dust collection engineers plus a network of technical sales representatives specifically selected for their industry experience. This combination of design, service and value establishes **Ultra Industries** as the innovative leader in the marketplace.

### *Design*

Ultra Industries has designed and built dust collectors from miniature sizes to one of the largest single compartment collectors built to date by any manufacturer.

### *Application*

Ultra Industries builds a collector for every application. Whatever the situation calls for, product recovery, air filtration or process dust control we are certain to have the solution to your problem.

# High Vacuum, High Pressure Collector for Pneumatic Conveying

MODELS CB AND CF

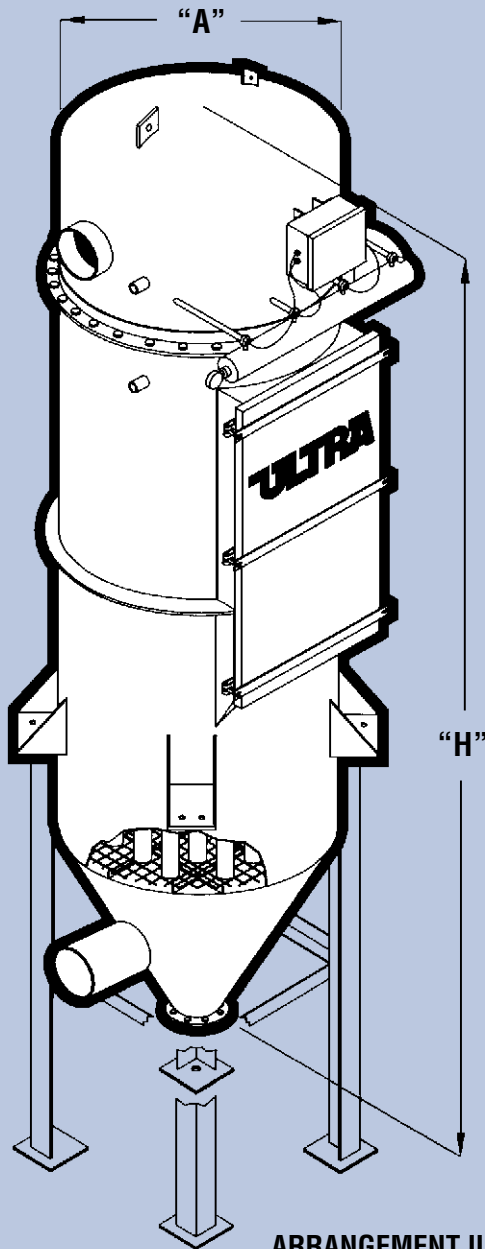

**ARRANGEMENT III G**  
(GRID PLATFORM OPTIONAL)

## Lowest Maintenance Cost

*... no moving parts. Convenient access doors for routine bag inspection.*

**MODEL CB**  
(5 3/4" Bags)

**MODEL CF**  
(4 1/2" Bags)

**Solid State Timer** helps save energy, easily adjusts to vary pulse intervals and pulse durations.

**Top Bag** removal available with walk-in plenum or easy lift off head for ease of maintenance.

Design Rating ± 100" W.G.

Design Rating ± 17" Hg.

Available platform and OSHA approved ladder

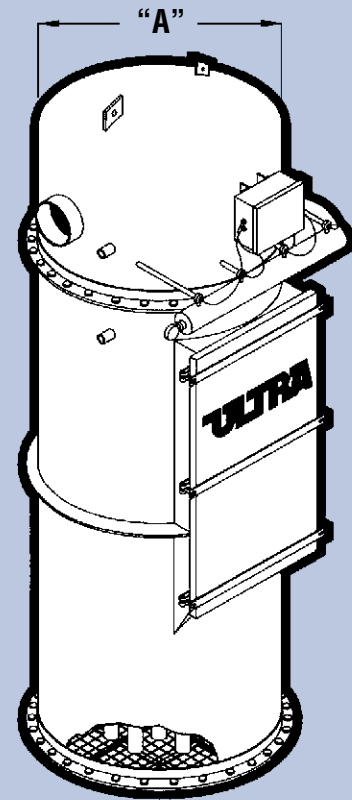

**ARRANGEMENT IIG**  
(GRID PLATFORM STANDARD)

### MODEL CB 5 3/4" Diameter Bags

| MODEL NO.              | CB7                                   | CB10         | CB14          | CB18         | CB24          | CB34         | CB39          | CB48         | CB58          | CB65         | CB80           | CB102          | CB124         | CB133         | CB164         |
|------------------------|---------------------------------------|--------------|---------------|--------------|---------------|--------------|---------------|--------------|---------------|--------------|----------------|----------------|---------------|---------------|---------------|
| COLLECTOR DIAMETER (A) | 2'0"                                  | 2'8"         | 3'0"          | 3'4"         | 4'0"          | 4'8"         | 5'0"          | 5'6"         | 6'0"          | 6'6"         | 7'0"           | 8'0"           | 8'6"          | 9'0"          | 10'0"         |
| 36" L BAGS             | AREA (SQ. FT.) 30<br>H (HEIGHT) 6'6"  | 43<br>7'3"   |               |              |               |              |               |              |               |              |                |                |               |               |               |
| 58" L BAGS             | AREA (SQ. FT.) 50<br>H (HEIGHT) 8'4"  | 72<br>9'1"   | 101<br>9'4"   | 130<br>9'10" | 173<br>10'5"  | 245<br>11'2" | 281<br>11'5"  | 346<br>12'1" | 418<br>12'8"  | 468<br>13'1" |                |                |               |               |               |
| 84" L BAGS             | AREA (SQ. FT.) 74<br>H (HEIGHT) 10'6" | 106<br>11'3" | 148<br>11'6"  | 191<br>12'0" | 254<br>13'7"  | 360<br>13'4" | 414<br>13'7"  | 509<br>14'3" | 615<br>14'10" | 689<br>15'3" | 848<br>15'10"  | 1081<br>16'11" | 1315<br>17'4" | 1410<br>17'9" | 1739<br>18'9" |
| 100" L BAGS            | AREA (SQ. FT.)<br>H (HEIGHT)          |              | 178<br>12'10" | 229<br>13'4" | 305<br>13'11" | 432<br>14'8" | 495<br>14'11" | 609<br>15'7" | 736<br>16'2"  | 825<br>16'7" | 1016<br>17'2"  | 1295<br>18'3"  | 1574<br>18'8" | 1689<br>19'1" | 2082<br>20'1" |
| 120" L BAGS            | AREA (SQ. FT.)<br>H (HEIGHT)          |              |               |              |               |              |               |              |               |              | 1225<br>18'10" | 1562<br>19'11" | 1899<br>20'4" | 2037<br>20'9" | 2512<br>21'9" |

# Compact Square Design For Bin Venting And Dust Control

**Maximum Filtering Efficiency**  
*removes up to 99.99% of dust particles at high air-to-cloth ratios.*

**Lowest Installed Cost**  
*...housing shipped assembled. Factory-installed air manifolds save hours of installation time.*

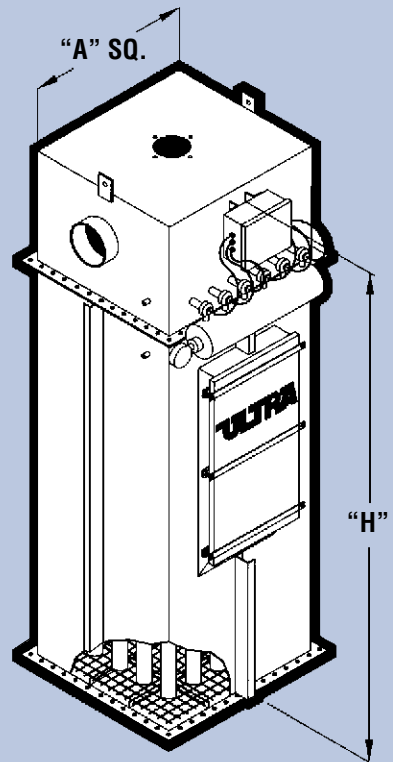

**ARRANGEMENT IIG**  
(GRID PLATFORM STANDARD)

**MODEL BB (5 3/4" Bags)**  
**MODEL SQ (4 1/2" Bags)**

**Standard Construction**  
 ... all welded 12 gauge steel. Stainless available for special applications.

**Convenient Access Doors**  
 permit quick entrance to dirty air plenum for routine bag inspection.

**Top Bag**  
 removal design available, utilizing lift-off doors. Models BD and SQD.

Available grid platform, structural support legs, platform and OSHA approved ladder

Design Rating  
 ± 20" W.G.

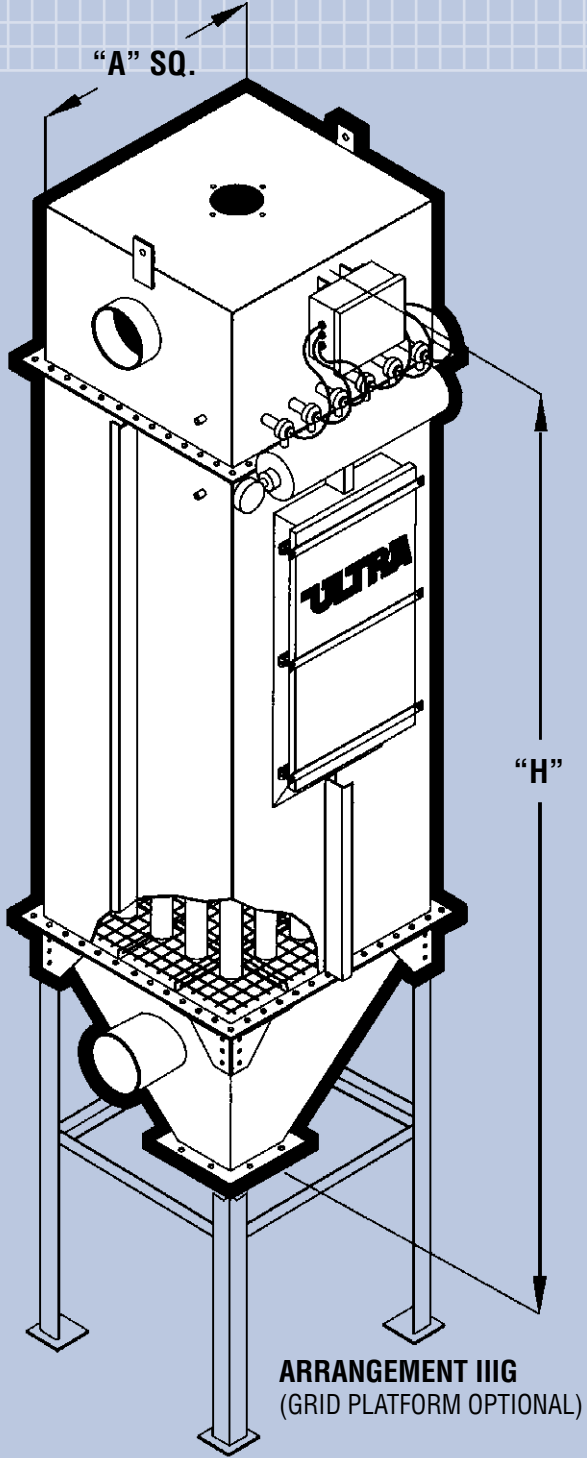

**ARRANGEMENT IIIIG**  
(GRID PLATFORM OPTIONAL)

| MODEL BB 5 3/4" Diameter Bags Arrangement IIG |                                      |            |              |              |              | Arrangement IIIIG |              |              |              |
|---|--------------------------------------|------------|--------------|--------------|--------------|-------------------|--------------|--------------|--------------|
| MODEL NO.                                     | BB4                                  | BB9        | BB16         | BB25         | BB36         | BB9               | BB16         | BB25         | BB36         |
| A (SQARE) (WIDTH)                             | 1'4"                                 | 2'0"       | 2'8"         | 3'4"         | 4'0"         | 2'0"              | 2'8"         | 3'4"         | 4'0"         |
| 36" L BAGS                                    | AREA (SQ. FT.) 17<br>H (HEIGHT) 5'3" | 39<br>5'3" |              |              |              | 39<br>6'5"        |              |              |              |
| 58" L BAGS                                    | AREA (SQ. FT.) 29<br>H (HEIGHT) 7'1" | 65<br>7'1" | 115<br>7'1"  | 180<br>7'1"  | 259<br>7'1"  | 65<br>8'3"        | 115<br>8'10" | 180<br>9'5"  | 259<br>10'0" |
| 84" L BAGS                                    | AREA (SQ. FT.)<br>H (HEIGHT)         | 95<br>9'4" | 170<br>9'4"  | 265<br>9'4"  | 382<br>9'4"  | 95<br>10'6"       | 170<br>11'1" | 265<br>11'8" | 382<br>12'3" |
| 100" L BAGS                                   | AREA (SQ. FT.)<br>H (HEIGHT)         |            | 203<br>10'8" | 317<br>10'8" | 457<br>10'8" |                   | 203<br>12'5" | 317<br>13'0" | 457<br>13'7" |

# All Welded Square Collectors For Intermediate Performance Requirements

MODELS BB AND SQ

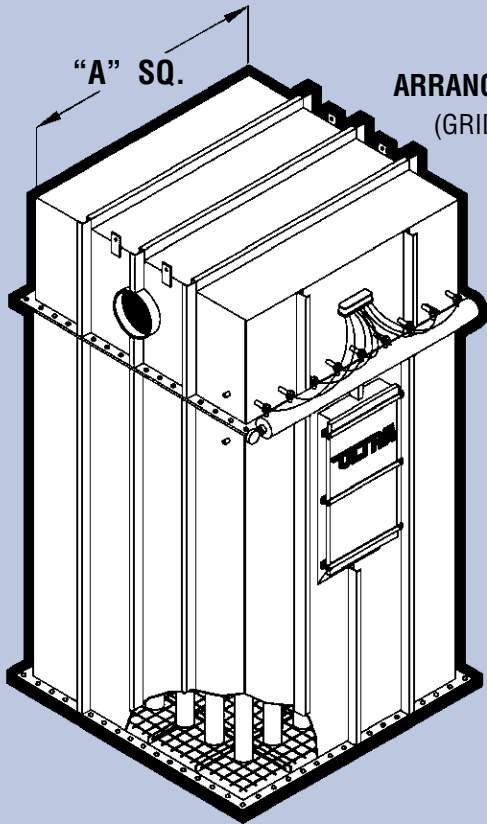

**ARRANGEMENT IIG**  
(GRID PLATFORM STANDARD)

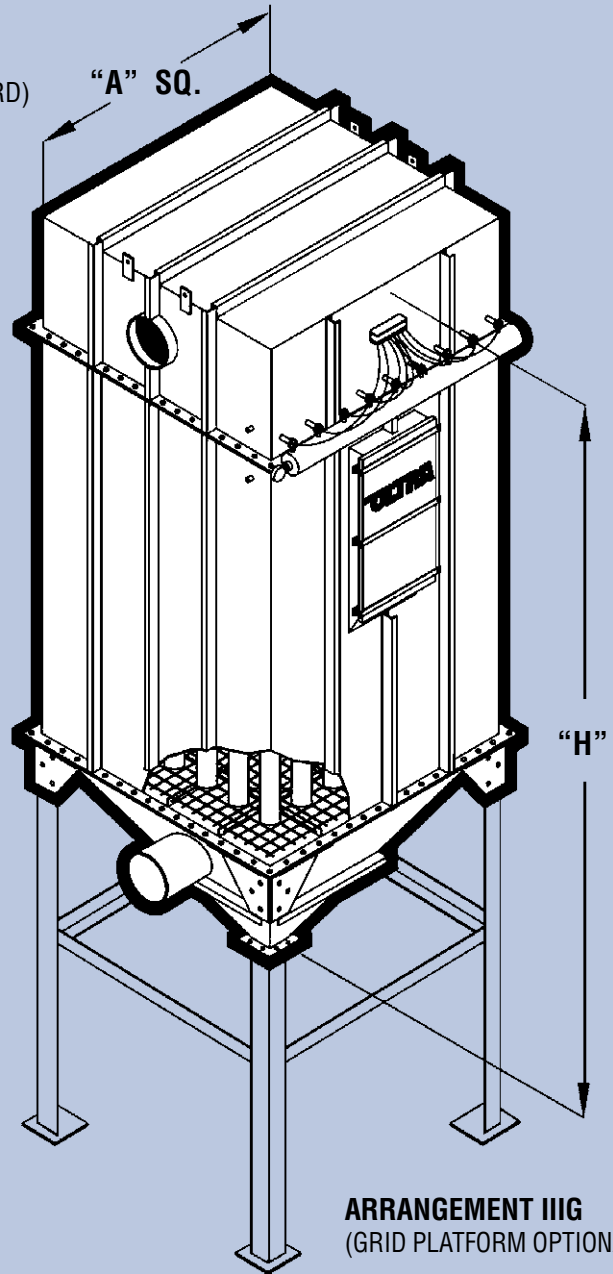

**ARRANGEMENT IIIG**  
(GRID PLATFORM OPTIONAL)

## MODEL BB (5 3/4" Bags) MODEL SQ (4 1/2" Bags)

### Side Bag

removal design utilizing convenient side access doors, for ease of bag changing.

### Top Bag

removal design, utilizing lift-off doors. Models BD and SQD or convenient walk-in plenum models BW and SQW.

Available grid platform, structural support legs, platform and OSHA approved ladder

Design Rating ± 20" W.G.

### MODEL BB 5 3/4" Diameter Bags

| MODEL NO.          | BB49                         | BB64         | BB81         | BB100         | BB121          | BB144         | BB169         | BB196         | BB225          | BB256         |               |
|--------------------|------------------------------|--------------|--------------|---------------|----------------|---------------|---------------|---------------|----------------|---------------|---------------|
| A (SQUARE) (WIDTH) | 4'8"                         | 5'4"         | 6'0"         | 6'8"          | 7'4"           | 8'0"          | 8'8"          | 9'4"          | 10'0"          | 10'8"         |               |
| 84" L BAGS         | AREA (SQ. FT.)<br>H (HEIGHT) | 520<br>12'8" | 679<br>13'3" | 859<br>15'0"  | 1060<br>15'7"  | 1283<br>16'2" | 1527<br>16'9" | 1792<br>17'3" | 2078<br>17'10" | 2386<br>18'5" | 2714<br>19'0" |
| 100" L BAGS        | AREA (SQ. FT.)<br>H (HEIGHT) | 622<br>14'0" | 813<br>14'7" | 1028<br>16'4" | 1270<br>16'11" | 1536<br>17'6" | 1828<br>18'1" | 2146<br>18'7" | 2489<br>19'2"  | 2857<br>19'9" | 3251<br>20'4" |
| 120" L BAGS        | AREA (SQ. FT.)<br>H (HEIGHT) | 750<br>15'8" | 980<br>16'3" | 1241<br>18'0" | 1532<br>18'7"  | 1853<br>19'2" | 2205<br>19'9" | 2588<br>20'3" | 3002<br>20'10" | 3446<br>21'5" | 3921<br>22'0" |

# All-Welded Rectangular Collector for Larger Performance Requirements

*Ultra offers a wide range of rectangular dust collector models providing filter areas from 3,927 square feet to over 16,000 square feet in one module. A collector can be selected to meet your exact space requirements. No other manufacturer offers this wide selection.*

## MODEL ND (5 3/4" Bags)

- Lift off doors - No tools required
- Standard safety railing
- Top bag removal makes maintenance easy, quick and clean
- One piece cage and venturi assembly
- Dirty bags can be dropped into hopper below and removed through hopper port
- Dust can be swept from top of tube sheet through holes into dusty air plenum below
- Bag snaps into tube sheet for positive seal

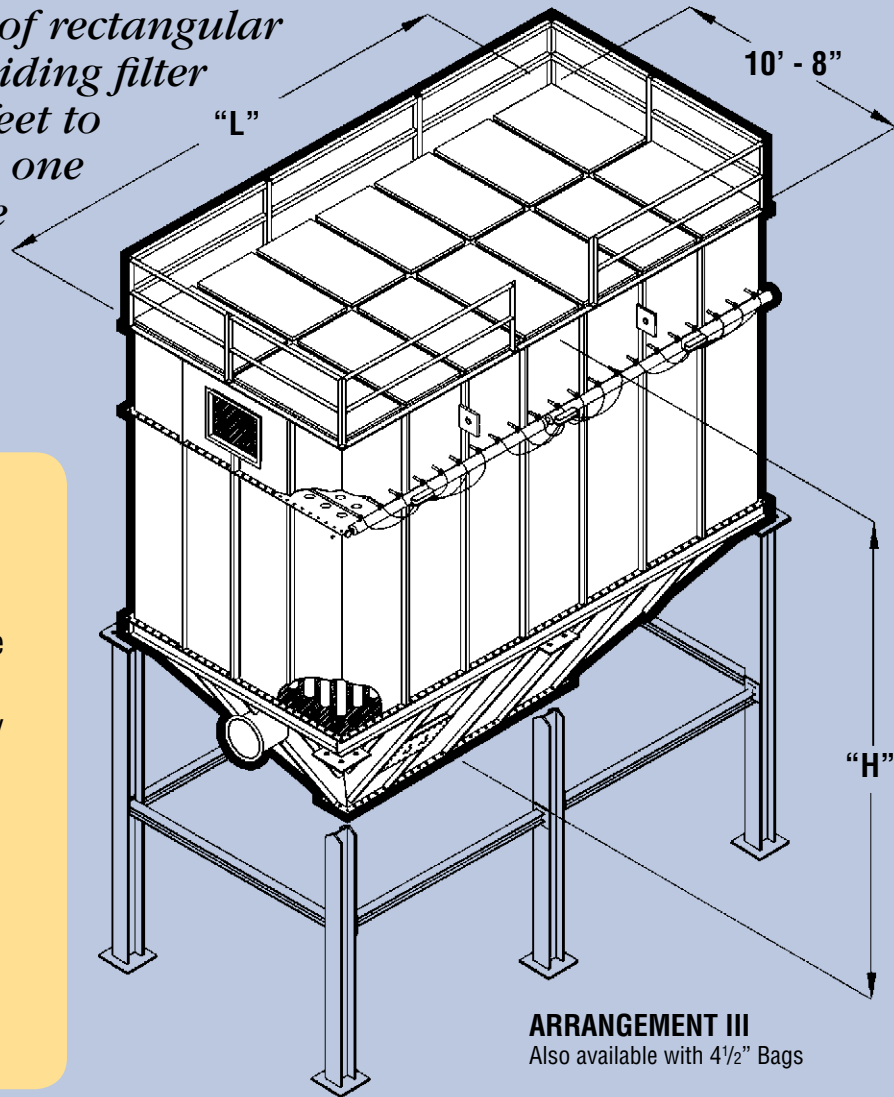

**ARRANGEMENT III**  
Also available with 4 1/2" Bags

## MODEL ND 5 3/4" Diameter Bags

| MODEL NO.   | ND300                        | ND330         | ND360         | ND390         | ND420         | ND450         | ND480         | ND510         | ND540         | ND570          |                |
|-------------|------------------------------|---------------|---------------|---------------|---------------|---------------|---------------|---------------|---------------|----------------|----------------|
| (L) LENGTH  | 14'0"                        | 15'4"         | 16'8"         | 18'0"         | 19'4"         | 20'8"         | 22'0"         | 23'4"         | 24'8"         | 26'0"          |                |
| 100" L BAGS | AREA (SQ. FT.)<br>H (HEIGHT) | 3927<br>19'0" | 4320<br>19'0" | 4712<br>19'0" | 5105<br>19'0" | 5498<br>19'0" | 5890<br>19'0" | 6283<br>19'0" | 6676<br>19'0" | 7069<br>19'0"  | 7461<br>19'0"  |
| 120" L BAGS | AREA (SQ. FT.)<br>H (HEIGHT) | 4712<br>20'8" | 5184<br>20'8" | 5655<br>20'8" | 6126<br>20'8" | 6597<br>20'8" | 7069<br>20'8" | 7540<br>20'8" | 8011<br>20'8" | 8482<br>20'8"  | 8954<br>20'8"  |
| 144" L BAGS | AREA (SQ. FT.)<br>H (HEIGHT) | 5655<br>22'8" | 6220<br>22'8" | 6786<br>22'8" | 7351<br>22'8" | 7917<br>22'8" | 8482<br>22'8" | 9048<br>22'8" | 9613<br>22'8" | 10179<br>22'8" | 10744<br>22'8" |

## MODEL ND 5 3/4" Diameter Bags (continued)

| MODEL NO.   | ND600                        | ND630          | ND660          | ND690          | ND720          | ND750          | ND780          | ND810          | ND840          | ND870          | ND900          |                |
|-------------|------------------------------|----------------|----------------|----------------|----------------|----------------|----------------|----------------|----------------|----------------|----------------|----------------|
| (L) LENGTH  | 27'4"                        | 28'8"          | 30'0"          | 31'4"          | 32'8"          | 34'0"          | 35'4"          | 36'8"          | 38'0"          | 39'4"          | 40'8"          |                |
| 100" L BAGS | AREA (SQ. FT.)<br>H (HEIGHT) | 7854<br>19'0"  | 8247<br>19'0"  | 8639<br>19'0"  | 9032<br>19'0"  | 9425<br>19'0"  | 9817<br>19'0"  | 10210<br>19'0" | 10603<br>19'0" | 10996<br>19'0" | 11388<br>19'0" | 11781<br>19'0" |
| 120" L BAGS | AREA (SQ. FT.)<br>H (HEIGHT) | 9425<br>20'8"  | 9896<br>20'8"  | 10367<br>20'8" | 10838<br>20'8" | 11310<br>20'8" | 11781<br>20'8" | 12252<br>20'8" | 12723<br>20'8" | 13195<br>20'8" | 13666<br>20'8" | 14137<br>20'8" |
| 144" L BAGS | AREA (SQ. FT.)<br>H (HEIGHT) | 11310<br>22'8" | 11875<br>22'8" | 12441<br>22'8" | 13006<br>22'8" | 13572<br>22'8" | 14137<br>22'8" | 14703<br>22'8" | 15268<br>22'8" | 15834<br>22'8" | 16399<br>22'8" | 16965<br>22'8" |

# Walk-In Plenum Provides Convenient, Safe Bag Changing and Inspection

MODEL NW

*The Ultra walk-in plenum top bag removal design provides the maximum convenience for dust collector maintenance. Bag changing is quickly accomplished in an "out of the weather" environment.*

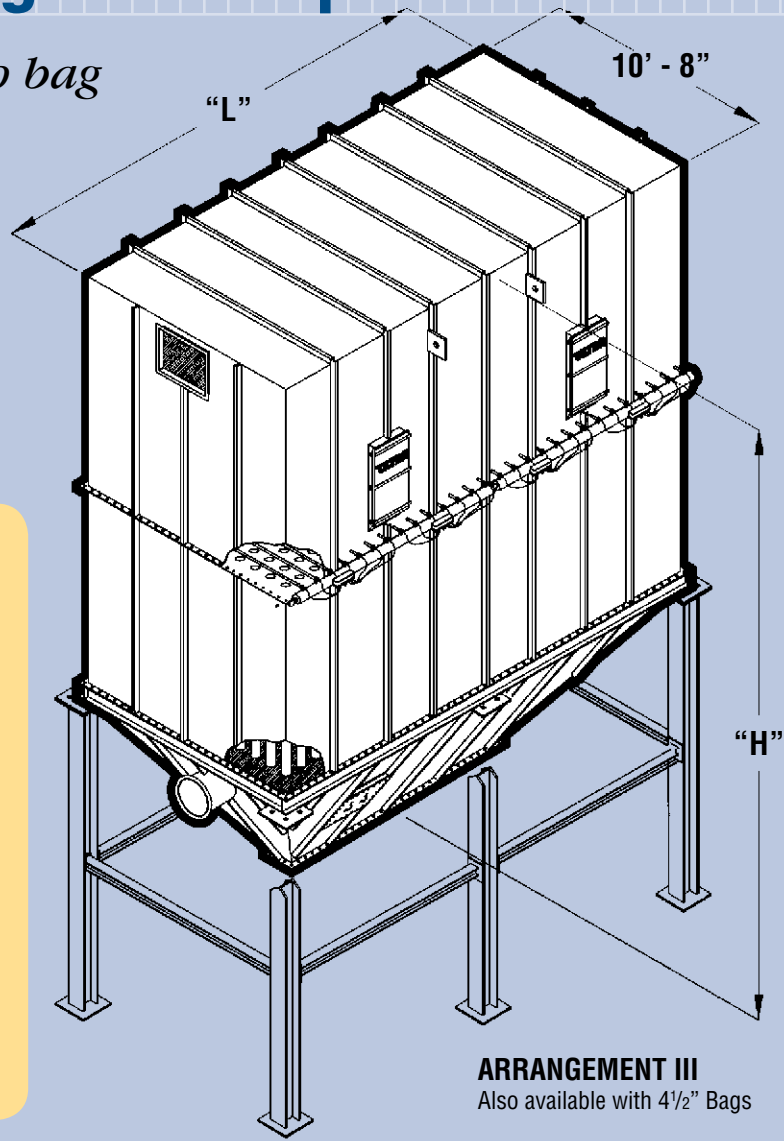

**ARRANGEMENT III**  
Also available with 4½" Bags

- MODEL NW (5¾" Bags)**
- Walk-in plenum permits maintenance personnel to service bags safely in any kind of weather conditions
  - Same easy bag changing features as the "ND" models
  - Durable 12 gauge all welded construction with stiffeners on 24" centers
  - Standard design pressure is ± 20" W.G.
  - Optional insulation can be factory installed
  - Easy installation - Shipped in 3 sections for quick field erection

**MODEL NW 5¾" Diameter Bags**

| MODEL NO.   | NW300                                   | NW330         | NW360         | NW390         | NW420         | NW450         | NW480         | NW510         | NW540          | NW570          |
|-------------|---|---------------|---------------|---------------|---------------|---------------|---------------|---------------|----------------|----------------|
| (L) LENGTH  | 14'0"                                   | 15'4"         | 16'8"         | 18'0"         | 19'4"         | 20'8"         | 22'0"         | 23'4"         | 24'8"          | 26'0"          |
| 100" L BAGS | AREA (SQ. FT.) 3927<br>H (HEIGHT) 25'1" | 4320<br>25'1" | 4712<br>25'1" | 5105<br>25'1" | 5498<br>25'1" | 5890<br>25'1" | 6283<br>25'1" | 6676<br>25'1" | 7069<br>25'1"  | 7461<br>25'1"  |
| 120" L BAGS | AREA (SQ. FT.) 4712<br>H (HEIGHT) 28'5" | 5184<br>28'5" | 5655<br>28'5" | 6126<br>28'5" | 6597<br>28'5" | 7069<br>28'5" | 7540<br>28'5" | 8011<br>28'5" | 8482<br>28'5"  | 8954<br>28'5"  |
| 144" L BAGS | AREA (SQ. FT.) 5655<br>H (HEIGHT) 32'5" | 6220<br>32'5" | 6786<br>32'5" | 7351<br>32'5" | 7917<br>32'5" | 8482<br>32'5" | 9048<br>32'5" | 9613<br>32'5" | 10179<br>32'5" | 10744<br>32'5" |

**MODEL NW 5¾" Diameter Bags (continued)**

| MODEL NO.   | NW600                                    | NW630          | NW660          | NW690          | NW720          | NW750          | NW780          | NW810          | NW840          | NW870          | NW900          |
|-------------|--|----------------|----------------|----------------|----------------|----------------|----------------|----------------|----------------|----------------|----------------|
| L (LENGTH)  | 27'4"                                    | 28'8"          | 30'0"          | 31'4"          | 32'8"          | 34'0"          | 35'4"          | 36'8"          | 38'0"          | 39'4"          | 40'8"          |
| 100" L BAGS | AREA (SQ. FT.) 7854<br>H (HEIGHT) 25'1"  | 8247<br>25'1"  | 8639<br>25'1"  | 9032<br>25'1"  | 9425<br>25'1"  | 9817<br>25'1"  | 10210<br>25'1" | 10603<br>25'1" | 10996<br>25'1" | 11388<br>25'1" | 11781<br>25'1" |
| 120" L BAGS | AREA (SQ. FT.) 9425<br>H (HEIGHT) 28'5"  | 9896<br>28'5"  | 10367<br>28'5" | 10838<br>28'5" | 11310<br>28'5" | 11781<br>28'5" | 12252<br>28'5" | 12723<br>28'5" | 13195<br>28'5" | 13666<br>28'5" | 14137<br>28'5" |
| 144" L BAGS | AREA (SQ. FT.) 11310<br>H (HEIGHT) 32'5" | 11875<br>32'5" | 12441<br>32'5" | 13006<br>32'5" | 13572<br>32'5" | 14137<br>32'5" | 14703<br>32'5" | 15268<br>32'5" | 15834<br>32'5" | 16399<br>32'5" | 16965<br>32'5" |

# "ULTRA FLOW" PULSE-JET CARTRIDGE COLLECTORS

**Model UVC  
Vertical Cartridge Collector**



*The "Ultra-Flo" UHC and UVC Cartridge Collectors are the perfect solution for your light loading applications for a variety of in plant air quality problems.*

*Compact design utilizes standard 12-3/4" diameter cartridges to offer more square feet of filter area per cubic foot of collector space. The modular design allows for multiple arrangements to handle airflows from 500 to 25,000 CFM.*

- Rugged high efficiency cartridge elements in a variety of media types offers efficiency to 99.99%.

- Rugged 12 ga. construction stiffened for up to 20" W.C. with 7 ga. tube sheet for added strength and parallel cartridge alignment.

- Specialized inlet with diffusion baffle provides for even air flow distribution resulting in the reduction of turbulence, re-entrainment and abrasion with lower energy usage.

- Easy access to cartridges simplifies maintenance.

- Solid state sequential timer housed in a NEMA 4 enclosure.

- Available as a bin vent or as a stand alone collector with hopper.

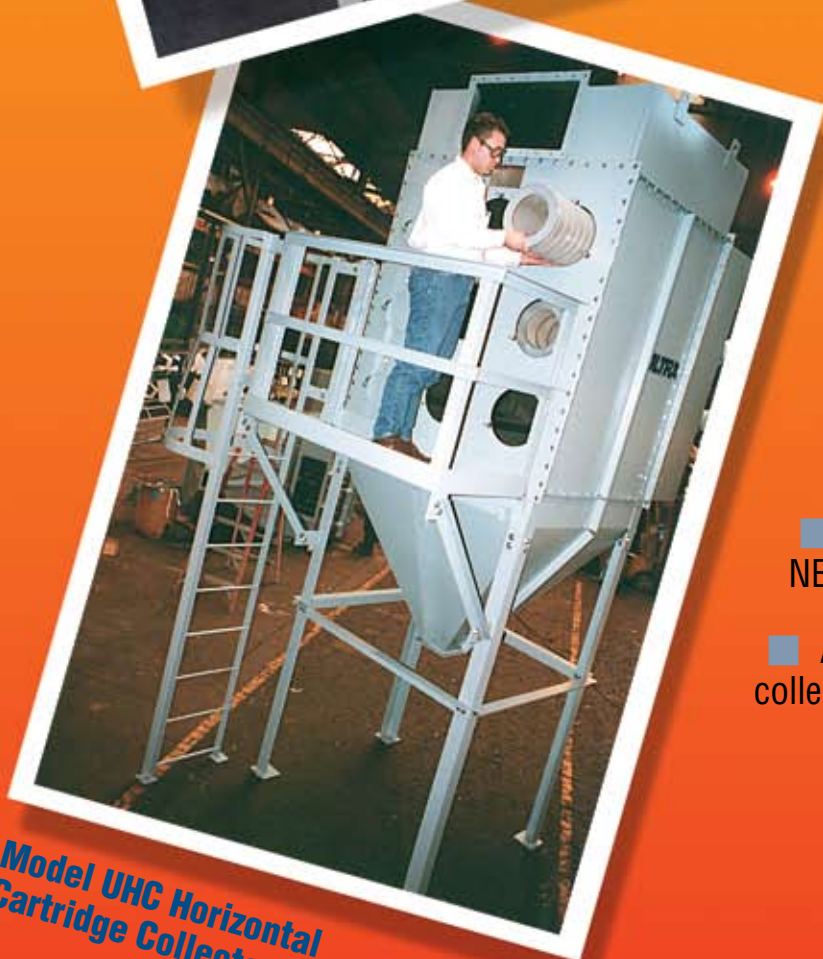

**Model UHC Horizontal  
Cartridge Collector**



# Model UVC and UHC *Ultra-Flo* Pulse-Jet Cartridge Collectors

MODELS UVC and UHC "ULTRA-FLO"

UVC and UHC also available as bin vents (Arrangement II)

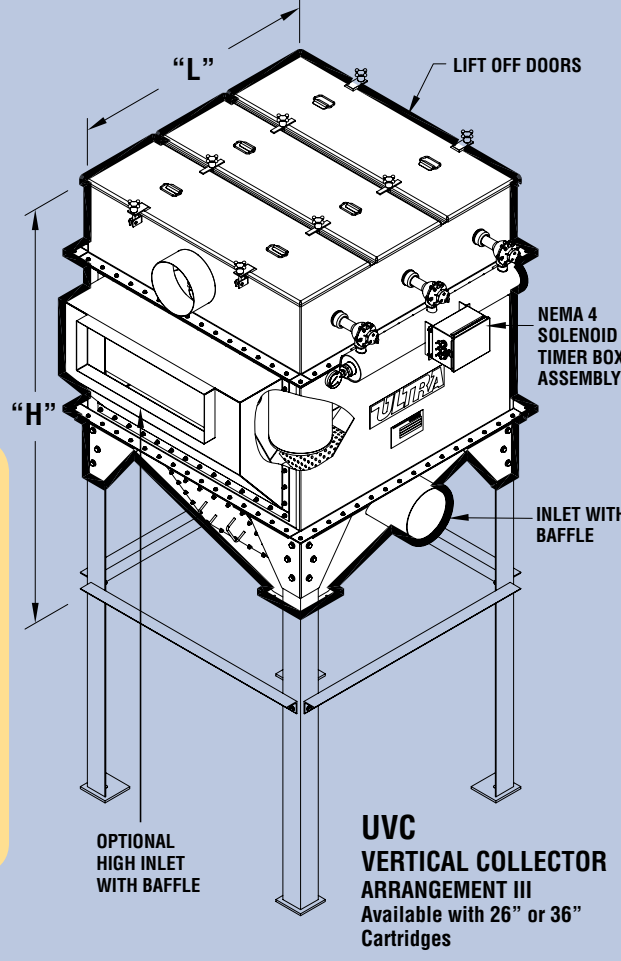
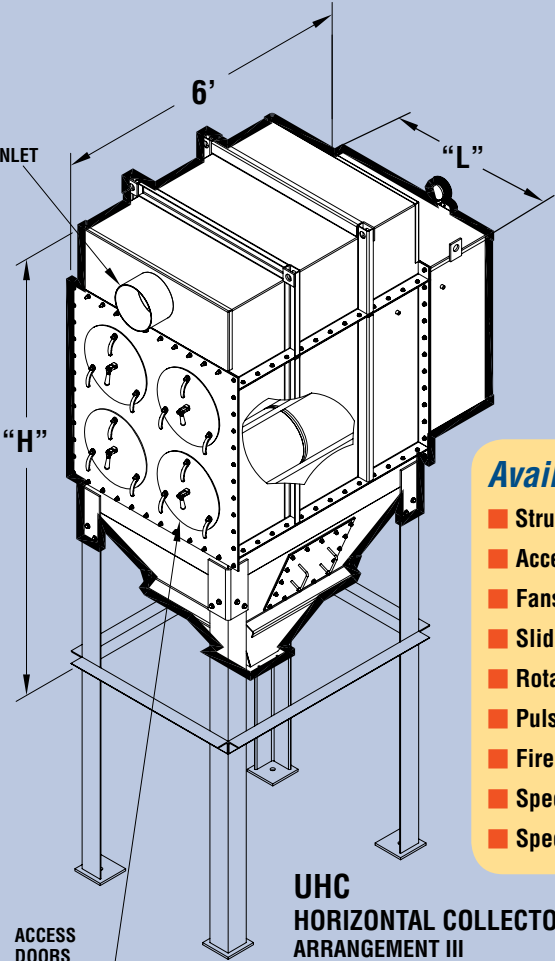

- Available Options:**
- Structural Support Legs
  - Access Platform and Ladder
  - Fans and Blowers
  - Slide Gates with Drum Covers
  - Rotary Airlocks
  - Pulse on Demand Cleaning
  - Fire and Explosion Relief Vents
  - Special Alloys and Materials
  - Special Paint and Coatings.

## MODEL UVC

| MODEL NO.             | UVC-2-226 | UVC-4-313 | UVC-9-226 | UVC-9-313 | UVC-16-226 | UVC-16-313 | UVC-25-226 | UVC-25-313 | UVC-36-226 | UVC-36-313 |
|-----------------------|-----------|-----------|-----------|-----------|------------|------------|------------|------------|------------|------------|
| NO. OF CARTRIDGES     | 4         | 4         | 9         | 9         | 16         | 16         | 25         | 25         | 36         | 36         |
| AREA (SQ. FT)*        | 904       | 1252      | 2034      | 2817      | 3616       | 5008       | 5650       | 7825       | 8136       | 11268      |
| LENGTH (L)            | 3'4"      | 3'4"      | 5'0"      | 5'0"      | 6'8"       | 6'8"       | 8'4"       | 8'4"       | 10'0"      | 10'0"      |
| ARRANG II HEIGHT (H)  | 4'8"      | 5'6"      | 4'8"      | 5'6"      | 4'8"       | 5'6"       | 4'8"       | 5'6"       | 4'8"       | 5'6"       |
| ARRANG III HEIGHT (H) | 7'0"      | 7'10"     | 8'5"      | 9'3"      | 9'11"      | 10'9"      | 11'4"      | 12'2"      | 12'9"      | 13'7"      |

## MODEL UHC

| MODEL NO.             | UHC-22 | UHC-32 | UHC-42 | UHC-33 | UHC-52 | UHC-43 | UHC-53 | UHC-44 | UHC-54 | UHC-64 |
|-----------------------|--------|--------|--------|--------|--------|--------|--------|--------|--------|--------|
| NO. OF CARTRIDGES     | 8      | 12     | 16     | 18     | 20     | 24     | 30     | 32     | 40     | 48     |
| AREA (SQ. FT)*        | 1808   | 2712   | 3616   | 4068   | 4520   | 5424   | 6780   | 7232   | 9040   | 10848  |
| LENGTH (L)            | 3'4"   | 5'0"   | 6'8"   | 5'0"   | 8'4"   | 6'8"   | 8'4"   | 6'8"   | 8'4"   | 10'0"  |
| ARRANG II HEIGHT (H)  | 6'1"   | 6'1"   | 6'1"   | 7'9"   | 6'1"   | 7'9"   | 7'9"   | 9'5"   | 9'5"   | 9'5"   |
| ARRANG III HEIGHT (H) | 9'10"  | 9'10"  | 9'10"  | 11'6"  | 9'10"  | 11'6"  | 11'6"  | 13'2"  | 13'2"  | 13'2"  |

\*Filter Areas Based on Cellulosic Filter Media. Other Filter Media Available.

# ULTRA-PLEAT FILTERS

## *Do You...*

- Need increased air flow and performance in your present bag house or filter/receiver?
- Have space or headroom limitations?
- Need to reduce bag house maintenance costs?
- Require washable filter elements?
- Need to save on energy costs?

*If you answered YES to any or all of the above questions you may need Ultra-Pleat Filters for your next change-over or new dust collector.*

Ultra-Pleat Filters require much less space per square foot of filter area than conventional bag filters. Their compact pleated design provides up to 59 square feet of filter area per filter, and they can operate at standard 4:1 or 5:1 air to cloth ratios.

Ultra-Pleat Filters are easy to install so they reduce the amount of time it takes your maintenance

personnel to perform a changeover. This saves you money! There are no cages. Only a one piece assembly which slips over a bag cup and is secured with a band clamp, or if the baghouse is a top removal design, the "Ultra-Pleat" filter's flexible top snaps into the tube sheet hole like a snapband bag. Either way you are insured of a positive seal.

Ultra-Pleat filters are durable and washable which can be important if you have frequent color or flavor changeouts.

Ultra-Pleats 100% spun bonded polyester media provides up to 99.99% particulate removal efficiency. Also available with PTFE laminate membrane.

Ultra-Pleats are perfect for retro-fitting an existing collector. It's as easy as removing the old filter bags and attaching the Ultra-Pleat Filters.



# ULTRA-PLEAT FILTERS DATA SHEET

## UPB-575 Bottom Removal Filters

Replaces 5-3/4" diameter bags. Fits industry standard bag cups. 1" pleat height.

| Filter Length | 30 Pleats    | 35 Pleats    | 45 Pleats    |
|---------------|--------------|--------------|--------------|
| 36"           | 14.0 sq. ft. | 16.3 sq. ft. | 21.5 sq. ft. |
| 58"           | 24.8 sq. ft. | 29.0 sq. ft. | 37.3 sq. ft. |
| 84"           | 38.1 sq. ft. | 44.0 sq. ft. | 56.6 sq. ft. |

## UPT-575 Top Removal Filters

Replaces 5-3/4" diameter bags. Fits 6-1/4" tube sheet hole. 1" pleat height.

| Filter Length | 30 Pleats    | 35 Pleats    | 45 Pleats    |
|---------------|--------------|--------------|--------------|
| 36"           | 17.8 sq. ft. | 20.1 sq. ft. | 26.7 sq. ft. |
| 58"           | 27.1 sq. ft. | 31.8 sq. ft. | 40.8 sq. ft. |
| 80"           | 39.6 sq. ft. | 46.2 sq. ft. | 59.4 sq. ft. |

### SPECIFICATIONS:

High strength, 100% spun bonded polyester  
 Continuous 200 degree F operating temperature  
 Excellent efficiency up to 99.99%  
 Polyurethane top and bottom construction  
 Galvanized metal inner core (304 SS & plastic optional)  
 Variable pleat height and pleat count  
 Food grade construction available  
 Custom designs available

### MEDIA OPTIONS:

|               |  |
|---------------|--|
| <b>SB</b>     | 100% spun bond polyester   |
| <b>SBME</b>   | 100% spun polyester with metalized media and ground wire for static dissipation  |
| <b>SBCB</b>   | 100% spun polyester with carbon impregnated finish and ground wire for static dissipation                                  |
| <b>SBTB</b>   | 100% spun bond polyester immersed in PTFE bath to create a hydro/oleo phobic coating for resistance to water, oil and dirt |
| <b>SBPTFE</b> | 100% spun bond polyester with PTFE membrane for ultra high efficiency, moisture resistance and dust release                |

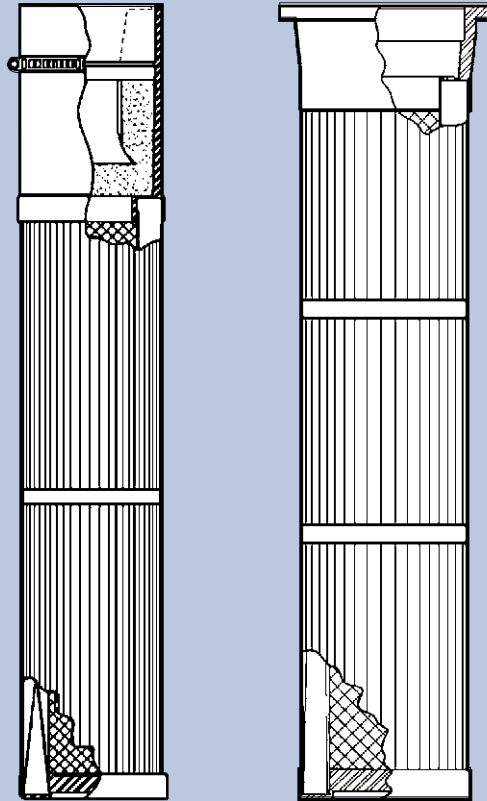

### Ultra-Pleat Filters Offer:

- More efficient filtration compared with felt
- Increased media area provides lower restriction
- Longer filter life
- Improved air flow capacity
- Superior dust release
- Reduced maintenance costs due to easier changeouts
- Washability
- No cages required with pleated filters
- Easy to remove and replace one piece design

### OTHER FABRICS OPTIONS:

Ryton, Nomex, Acrylic, P84

## *From Concept to Completion, The Ultra Advantages...*

- Two Bag Diameters - 4 1/2" and 5 3/4" Diameter
- Lowest Installed Cost - Housings are Shipped Completely Assembled
- Advanced Top Bag Removal System - Snap Ring Bags and Drop-in Cages Permit Bags to be Installed Quickly and Ensure Leak-Proof Seals

### *Additional Features And Options*

- Solid State Timer - Saves Energy, Easily Adjusts to Vary Pulse Interval and Duration
- Protective Service Grid Under Bags
- Inlet Baffle with Abrasion-Resistant Target Plate
- Outlet with Weatherhood and Bird Screen
- Differential Pressure Switch - Signals Rise in Pressure across Filter
- Roof or Side Mounted Exhaust Fans
- Sanitary Sloped Door Ledges
- NEMA 4 Controls Standard – NEMA 7 and 9 Controls Optional
- Stainless Steel Construction Available
- Explosion Venting Designed to Rigid NFPA Standards
- Support Legs
- Slide Gates
- Access Platforms
- Airlocks
- Caged Ladders
- Screw Conveyor

### **ULTRA INDUSTRIES, INC.**

Racine, Wisconsin USA

Ph: (800) 358-5872

[www.ultradustcollectors.com](http://www.ultradustcollectors.com)

[parts@ultraind.com](mailto:parts@ultraind.com)

[sales@ultraind.com](mailto:sales@ultraind.com)